

SNAIGĒ



WD35SM

Instruction for Use

Dear Customer,

CAREFULLY READ THE INSTRUCTION MANUAL. If instructions are not followed, there is a risk of injury, damage of the appliance and loss of the right to free warranty service.

The Manufacturer shall not be held liable for damage arising from the failure to observe the instructions contained in this manual.

We recommend to keep the Instruction manual the whole time you have the appliance. When you sell the appliance pass the Instruction manual to the new owner of the appliance.

General information:

The appliance is a compressor-type refrigerator with glass doors: are designed for storage and chilling of wine. The appliances may be used in cafes, bars and etc.

THE MANUFACTURER GUARANTEES RELIABLE OPERATION OF THE REFRIGERATOR WHEN THE AMBIENT TEMPERATURE IS +16 TO +32 DEGREES CELSIUS AND THE RELATIVE AIR HUMIDITY NOT GREATER THAN 70 PER CENT.

CE conformity. At the time of its market launch, this appliance complies with the requirements stipulated in the guidelines of the council for the harmonization of the legal provisions of the member states on electromagnetic compatibility Directive 2014/30 / EU and on the use of electrical equipment within certain voltage limits Directive 2014/35 / EU. This appliance is marked with the CE mark and has a declaration of conformity for inspection by the responsible market surveillance authorities.

SAFETY INSTRUCTIONS

General safety requirements:

- WARNING: Do not cover the ventilation holes at the top and on the sides of the appliance.
- WARNING: Do not use any mechanical means or electrical devices to hasten the thawing process when cleaning the freezer compartment.
- WARNING: Do not use electrical appliances inside the food storage compartments of the appliance, unless they are of the type recommended by the manufacturer.
- WARNING: When positioning the appliance, ensure the supply cord is not trapped or damaged.
- WARNING: Do not locate multiple portable socket-outlets or portable power supplies at the rear of the appliance.
- WARNING: Disposal of the appliance should be according to national rules.

- This appliance is not designed for the storage of explosive substances such as aerosol cans with a flammable propellant.
- It is prohibited to store petrol and other flammable liquids near the appliance.
- The appliance should be used only for storing wine.



WARNING: risk of fire / flammable materials. Do not damage the appliance refrigeration system. It contains the refrigerant gas R600a. If the refrigeration system is damaged:

- Do not use any open flame.
- Avoid sparks — do not turn on any electrical appliances or lighting fixtures.
- Immediately ventilate the room.
- Air the room in which the appliance is placed for a few minutes (the size of the room for a product containing isobutane / R600a must be at least 4 m³) to avoid damage to the cooling system.



C-Pentane is used as blowing agent in the insulation foam and it is a flammable gas.

Children and vulnerable people safety:

- Do not allow children to play with the appliance or to plug it in or unplug from the electricity supply socket. Do not allow children to play with the packaging material from the appliance. Cleaning and user maintenance shall not be made by children without supervision
- This appliance can be used by children aged from 8 years and above and persons with reduced physical, sensory or mental capabilities or lack of experience and knowledge if they have been given supervision or instruction concerning use of the appliance in a safe way and understand the hazards involved.
- Children aged from 3 to 8 years are allowed to load and unload refrigerating appliances.



Requirements for the connection to the mains:

- The appliance should only be connected to an earthed socket installed in accordance with the regulations. This product complies with all binding CE labelling directives. The earthed electrical socket by which the appliance is connected to the mains should be in an accessible place. It is a legal requirement that the appliance is properly earthed. The manufacturer will not be held liable for any damage or injury which may result from the failure to fulfil this requirement.

- The frequency and power of the electricity supply must conform to the general data parameters of the appliance as it is shown in the product label.
- **WARNING:** If the supply cord is damaged: to avoid the exposure to danger, always have faulty cable be replaced only by the manufacturer, by our customer service or by qualified person and with a cable of the same type.
- Do not use adapters, multiple sockets and two-wire extension leads. If it is necessary to use the extension lead, it must be equipped with a protection ring and a single socket and must have a VDE/GS safety certificate.
- When positioning the appliance, be careful that the electrical cord isn't squeezed in order to avoid its damage. Do not store heavy objects such as cooling devices, furniture or other devices next the appliance in such a way that they could squeeze and damage the electrical cord. This can cause a short circuit and a fire.
- Make sure that the plug of the electrical cord is not squeezed by the back wall of the appliance or otherwise damaged. A damaged plug can be the cause of a fire!
- **CAUTION!** If the installed interior lighting diode (LED) lamp for the cooling device is not functioning, contact the maintenance and repair representative for replacements. **LAMPS CAN BE REPLACED ONLY BY THE MAINTENANCE AND REPAIR REPRESENTATIVE.**

Requirements for safe use:

- Once the appliance is unpacked, make sure that it is complete, that the body and the electrical cord aren't damaged. It is forbidden to use a technically damaged appliance.
- If the appliance is unplugged (for cleaning, moving to another place, etc.), **IT MAY BE REPEATEDLY SWITCHED ON AFTER 15 MIN.**
- When performing activities, such as cleaning, maintenance or moving, the appliance must be completely disconnected from power supply (by pulling the plug out from the socket). Do not pull on the cord, but hold the body of the plug instead.
- Do not set up the device outdoors.
- In an emergency, pull the power plug out of the socket immediately.
- Do not place any switched on electrical devices on top of the appliance because this may cause ignition of plastic parts.
- Do not place any dishes with liquids on top of the appliance and do not keep flowers in vases or other liquid-filled vessels on the appliance.
- Do not climb on or sit on the appliance, do not lean on or hang on the appliance doors and do not allow children to do this.

- Do not use water spray and steam to clean the appliance.
-  Do not try repair the appliance on your own. If the appliance is out of order and it is not possible to repair it by means of given recommendations, unplug it, open the doors and call the service expert. Only a service representative can remedy all technical or construction faults.
-  **The appliance should be transported only in the vertical position;** do not tilt any more than 30°. The manufacturer will not be responsible for any damage of the appliance that results from non-compliance with the instructions for transportation.

INSTALLATION AND OPERATING CONDITIONS

Positioning:

This appliance can be installed in a dry, well ventilated indoor where the ambient temperature corresponds to the climate class indicated on the rating plate of the appliance. Do not use it in the cellar, unheated summer cottage during autumn and winter.

-  **WARNING!** The appliance should not be operated in an unheated room or porch. Place the appliance away from heat sources such as kitchen stove/oven, radiators, or direct sunlight. The appliance must not touch any pipes for heating, gas or water supply or any other electrical devices.

Minimum distances from the heat sources:

- from the electric gas and other ovens - 30 mm,
- from oil or coal fired ovens - 300 mm,
- from built-in ovens - 50 mm

If there is no possibility of ensuring the above- mentioned distances, provide an appropriate insulation board.

- Do not cover the ventilation holes at the top of the appliances – it must be a good air circulation around the appliance. There should be a gap of at least 10 cm between the top of the appliance body and any furniture that may be above it. If this requirement is not followed, the appliance consumes more electrical energy and its compressor may overheat.
- If the appliance is placed in a corner, a gap of at least 60 mm must be left between the appliance body and the wall. **External dimensions for installation ►**
- The appliance must stand on a level surface and must not touch the wall. If necessary, regulate the height of the appliance by adjusting the levelling feet: by turning them clockwise – the front of the appliance rises, by turning them counter clockwise – it comes down. If the appliance is tilted slightly backward – the doors will close by themselves.

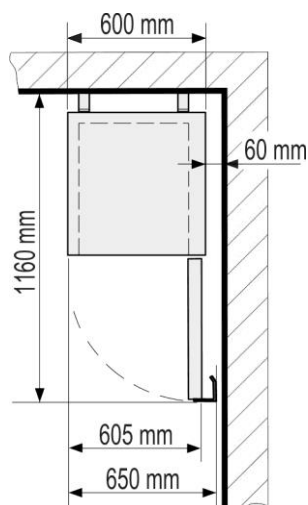



Preparing the appliance for operation:

It is recommended to prepare the appliance for operation with a helper.

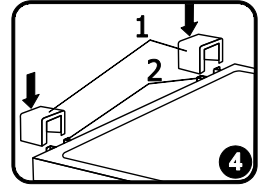
- The device must only be transported in its vertical position; do not tilt any more than 30°.
- Remove package. Lift the appliance away from foamed polystyrene base. **When placing, moving, lifting the appliance, do not hold the door handles, do not pull the condenser at the rear part of the refrigerator and do not touch the compressor unit.** Therefore take out adhesive tapes from sides and simply lift the appliance up and take out the board. Strip adhesive tapes off and open the door. Remove the spacer above the door.
- When positioning the appliance in chosen location, it will move more easily into position if you lift the front a little and incline it backward allowing it to roll on its casters.
- Take two supports from the bag and insert them into the guides at the top back part of the appliance (see fig. 4).



-  The appliance **should not be connected to the mains** until all packing and transport materials aren't removed. Suitably dispose the packaging material.
- Once the unit has been positioned, wait for about 30 minutes before it is connected to the mains.
-  **If the device has been tilted more than 30° during transport, allow it to stand in an upright position for at least 4 hours before it is connected to the mains.** If this is not done, the appliance compressor may fail.
- When first starting-up or after a period out of use, before putting the products in the compartment let the appliance run at least 2 hours.

DESCRIPTION OF THE APPLIANCE, BASIC PARTS

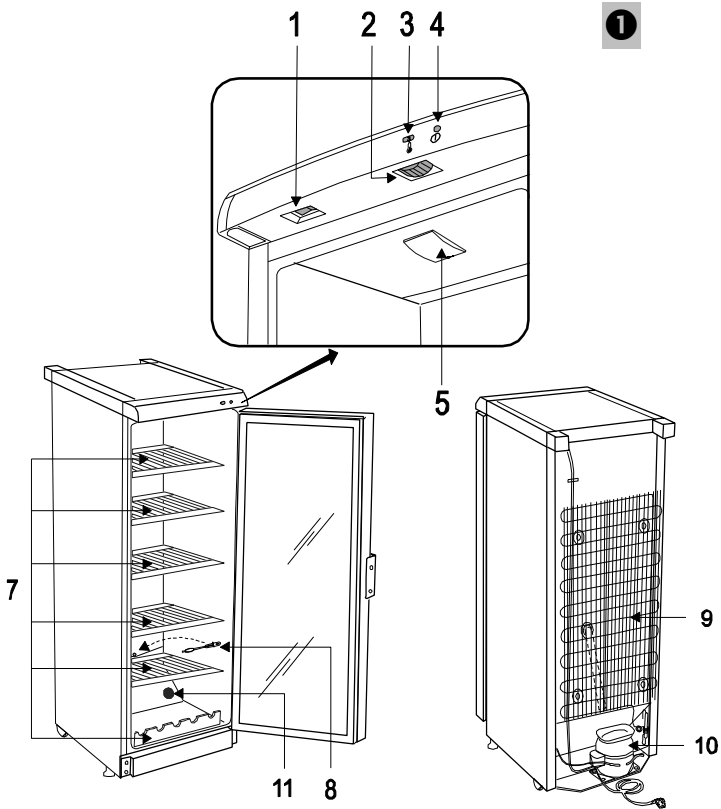

1 On/ off switch for interior light I -(ON) O -(OFF)	7 Adjustable height shelves
2 Thermostat knob	8 Thaw water channel cleaner
3 Thermostat indicator	9 Condenser
4 Electricity supply indicator *	10 Compressor
5 Interior light block (LED)	11 Carbon filter

* When the appliance is connected to the electricity supply, the green indicator light is illuminated.

Keys you will find on the shelf of the appliance.

NOTE. Door position is not reversible for refrigerators with mechanical lock.

NOTE. The technical data of the appliance can be found on the rating label attached to the inside wall of the appliance. For more information about the appliance, scan the QR code on the enclosed energy label and / or visit the official website of the product database: <https://eprel.ec.europa.eu>

TEMPERATURE REGULATION

The temperature in the appliance compartment is controlled using the thermostat knob **2** (see fig. 1, page 1) by turning it to one side or the other. Turning the thermostat knob clockwise the temperature in the compartment lowers. The temperature indication in digits is shown beside the thermostat knob. When the door is closed, the temperature setting can be seen on the thermostat indicator display **3** (see fig. 1, page 1).

The numbers "0, 1, 2, 3, 4, 5," do not mean a specific temperatures.

The temperature is regulated on the scale of five digits.

0 = Compressor is switched off **WARNING! Electric current is not switched off.**

1 = highest temperature (lowest cooling)

5 = lowest temperature (highest cooling)

 THE TEMPERATURE IN THE APPLIANCE COMPARTMENT MAY VARY DEPENDING ON AMBIENT TEMPERATURE, THE AMOUNT OF WINE AND HOW OFTEN THE APPLIANCE DOORS ARE OPENED AND CLOSED.

 If the room is cool, the appliance cools less. The temperature in the appliance may therefore rise. Use the thermostat wheel to set a lower temperature.

Wine temperature, °C

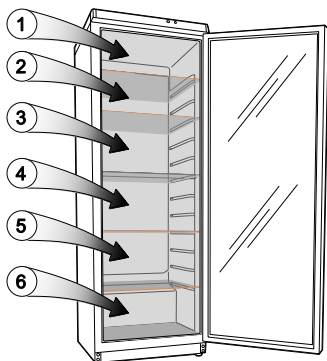

Zone designation	Position of the thermostat (ambient temperature +25 °C)				
	1	2	3	4	5
1 zone	12 - 14	12 - 14	12 - 14	10 - 12	8 - 10
2 zone	10 - 12	10 - 12	9 - 11	8 - 10	6 - 8
3 zone	8 - 10	8 - 10	8 - 10	6 - 8	4 - 6
4 zone	8 - 10	8 - 10	6 - 8	4 - 6	4 - 6
5 zone	8 - 10	8 - 10	4 - 6	2 - 4	2 - 4
6 zone	6 - 8	6 - 8	4 - 6	2 - 4	1 - 3

DEFROSTING, CLEANING AND CARE

THE APPLIANCE COMPARTMENT DEFROSTS AUTOMATICALLY. Drops of ice that form on the back wall of the refrigerator compartment thaw during the time the compressor is not working and the thaw water runs down the thaw water runoff channel to the tray on top of the compressor, where it evaporates.

REGULARLY CLEAN THE APPLIANCE.



Remember that before cleaning the back part of the appliance body you must disconnect the appliance from the electrical energy supply socket by pulling the plug out of the electricity outlet.

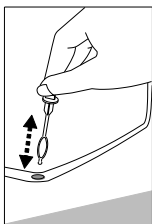

- Protect the appliance inner surfaces and plastic parts from fats, acids and sauces. In case of accidental spills – immediately clean. Clean the appliance inner surfaces.
- Regularly clean the hermetic gaskets of the doors. Wipe dry.
- ◀ **REGULARLY CLEAN THE THAW WATER CHANNEL SPACE WITH A SPECIAL CLEANER 8 FOR THAT PURPOSE** (see fig. 1).
- At least once a year clean dust away from the back part of the appliance body and the compressor. A soft brush, electrostatic cloth or vacuum cleaner may be used for cleaning.
- DO NOT use detergents containing abrasive particles, acid, alcohol or benzene for cleaning the appliance inner and outer surfaces. Outer of the doors – glass – clean with agents intended for glass cleaning. DO NOT use for cleaning cloths or sponges that have coarse surfaces intended for scrubbing.
- If the refrigerating appliance is left empty for long periods, switch off, defrost, clean, dry, and leave the door open to prevent mould developing within the appliance.

OPERATION PROBLEMS AND THEIR SOLUTIONS. What if ...

- **The appliance is plugged in to the mains but it does not work and the electricity supply voltage indicator is not illuminated.** Check that your house electricity supply installations are in order. Check that the plug is correctly inserted into the electricity supply socket.
- **The noise has become louder.** Check that the appliance is standing stable, on a level place. To make it level, regulate the front feet. Check if the appliance is not touching any furniture, and that no part of the refrigeration system at the back part of the appliance body is touching the wall. Pull the appliance away from any furniture or walls. Check that the cause of increased noise isn't due to bottles, cans in the appliance that might be touching each other.
- **Water has appeared at the bottom of the refrigerator compartment.** Check whether a thaw water channel space isn't blocked. Clean the thaw water channel space with a cleaner intended for that purpose.
- **Water has appeared under the appliance.** The thaw water collection tray has slipped off the compressor. Place the tray on top of the compressor.
- **When the appliance door is opened, the rubber sealing gasket pulls out.** The gasket is smeared with sticky foodstuffs (fat, syrup). Clean the sealing gasket and the groove for it with warm water containing soap or dishwashing detergent and wipe dry. Put the rubber sealing gasket back into the place.

- **High temperature in appliance, the compressor operation pauses are short.** Ascertain whether the appliance door/doors are shutting tightly, whether the door wasn't kept open longer than necessary when taking out or putting in foodstuffs.
- **The top of the appliance has condensation on it.** The ambient relative air humidity is above 70 %. Ventilate the room where the appliance stands and if possible remove the cause of the humidity.



Remarks on the appliance operating noise. As the appliance operates and goes through the freezing cycle, various noises will be emitted. This is normal and is not a sign of any malfunction.

- As the refrigerant circulates around the refrigeration system, it causes sounds like murmuring, bubbling, or rustling. Louder sounds like popping or clicking may be heard for a short time as the refrigerator compressor switches on.

ENVIRONMENTAL PROTECTION INFORMATION

Important Note:

This appliance is marked according to the European directive 2002/96/EC on Waste Electrical and Electronic Equipment (WEEE). By ensuring this product is disposed of correctly, you will help prevent potential negative consequences for the environment and human health, which could otherwise be caused by inappropriate waste handling of this product.



The symbol on the product, or on the documents accompanying the product, indicates that this appliance may not be treated as household waste. Instead it shall be handed over to the applicable collection point for the recycling of electrical and electronic equipment.

Disposal must be carried out in accordance with local environmental regulations for waste disposal. For more detailed information about treatment, recovery and recycling of this product, please contact your local authority, your household waste disposal service or the retailer where you purchased the product.

Our packaging are made of environmentally friendly materials, which can be reused:

- The external packaging is made of cardboard/foil
- The FCKW free shape of foamed polystyrene (PS)
- Polyethylene (PE) foils and bags

The refrigerants and foaming agents, which are 100% free of FCKW and FKW have been used for manufacturing our product. Therefore we are helping to protect the ozone layer and prevent the increase of greenhouse effects. Also, the innovative technology and environmentally friendly insulation help in reducing energy consumption.

RISK FROM OLD APPLIANCE!

Keep children under the age of 8 away from the power cord of the appliance. Keep children away from the packaging materials. Playing children can lock themselves in the device or get into other life-threatening situations.

- Remove or destroy existing snap locks and bolt locks.
- Do not let children play with the appliance.
- Always supervise children in the vicinity of the old appliance.