

SNAIGĒ
ICE LOGIC

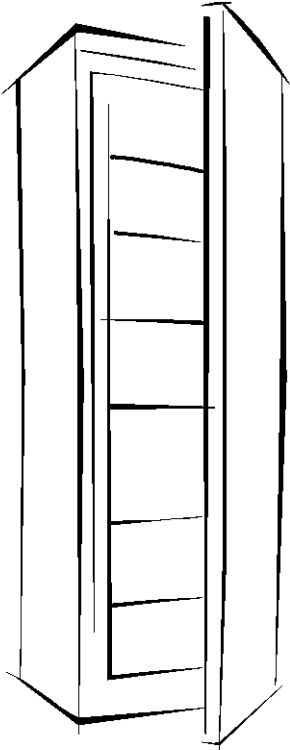

F 22SM

F 27SM

F 10SM

UPRIGHT FREEZER

Instruction for Use

DEAR CUSTOMER!

Some provisions in this user manual are unified for refrigerating products of different types (for a refrigerator, refrigerator-freezer or freezer). CAREFULLY READ THE INSTRUCTION MANUAL.

The Manufacturer shall not be held liable for damage arising from the failure to observe the instructions contained in this manual.

Keep this manual for future reference, or to pass it over to the next user.

General information:

Refrigeration appliance - a household freezer intended for household use. The freezer compartment is designed for freezing and storing food for a long time.

The device can be used, for example, in the dining rooms of staff in shops, offices and other establishments, in the kitchens of student dormitories, in hotels, in country houses, in guesthouses and in the kitchens of other living quarters.

CE conformity. At the time of its market launch, this appliance complies with the requirements stipulated in the guidelines of the council for the harmonization of the legal provisions of the member states on electromagnetic compatibility Directive 2014/30 / EU and on the use of electrical equipment within certain voltage limits Directive 2014/35 / EU. This appliance is marked with the CE mark and has a declaration of conformity for inspection by the responsible market surveillance authorities.

GUIDELINES CONCERNING THE SAFETY OF USE

General safety requirements:

- WARNING: Keep ventilation openings, in the appliance enclosure or in the built-in structure, clear of obstruction.
- WARNING: Do not use mechanical devices or other means to accelerate the defrosting process, other than those recommended by the manufacturer.
- WARNING: Do not use electrical appliances inside the food storage compartments of the appliance, unless they are of the type recommended by the manufacturer.
- WARNING: When positioning the appliance, ensure the supply cord is not trapped or damaged.
- WARNING: Do not locate multiple portable socket-outlets or portable power supplies at the rear of the appliance.



WARNING: Do not damage the appliance refrigeration system. It contains the refrigerant gas R600a. If the refrigeration system is damaged:

- Do not use any open flame.
- Avoid sparks-do not turn on any electrical appliances or lighting fixtures.

- Immediately ventilate the room: air the room in which the appliance is placed for a few minutes (the size of the room for a product containing isobutane / R600a must be at least 4 m³) to avoid damage to the cooling system.



C-Pentane is used as blowing agent in the insulation foam and it is a flammable gas.

- WARNING: Disposal of the appliance should be according to national rules.
- This appliance is not designed for the storage of explosive substances such as aerosol cans with a flammable propellant.
- It is prohibited to store petrol and other flammable liquids near the appliance.
- The appliance should be used only for storing foodstuffs.

Children and vulnerable people safety:

- Do not allow children to play with the appliance or to plug it in or unplug from the electricity supply socket. Do not allow children to play with the packaging material from the appliance.
- This appliance can be used by children aged from 8 years and above and persons with reduced physical, sensory or mental capabilities or lack of experience and knowledge if they have been given supervision or instruction concerning use of the appliance in a safe way and understand the hazards involved.
- Cleaning and user maintenance shall not be made by children without supervision.
- Children aged from 3 to 8 years are allowed to load and unload refrigerating appliances.

Requirements for the connection to the mains:

- The appliance should only be connected to an earthed socket installed in accordance with the regulations. Make sure that the supply voltage corresponds with the voltage marked on the rating label. This product complies with all binding CE labelling directives. The earthed electrical socket by which the appliance is connected to the mains should be in an accessible place. It is a legal requirement that the appliance is properly earthed. The manufacturer will not be held liable for any damage or injury which may result from the failure to fulfil this requirement.
- To avoid the exposure to danger, always have faulty cable be replaced only by the manufacturer, by our customer service or by qualified person and with a cable of the same type.
- It is forbidden to readjust or modify any parts of the unit. It is crucial not to damage the capillary tube visible in the compressor recess. The tube may not be

bent, straightened or wound. If the capillary tube is damaged by the user the guarantee will be void.

- Do not use adapters, multiple sockets and two-wire extension leads. If it is necessary to use the extension lead, it must be equipped with a protection ring and a single socket and must have a VDE/GS safety certificate. If an extension lead is used (with a protection ring and safety certificate), its socket must be located at a safe distance, away from the sinks, and must not be in a place where it could be flooded by water or waste water.
 - The frequency and power of the electricity supply in your house must conform to the general data parameters of the appliance as it is shown in the product label.
 - When positioning the appliance, be careful that the electrical cord isn't squeezed in order to avoid its damage. Do not store heavy objects such as cooling devices or other devices next the appliance in such a way that they could squeeze and damage the electrical cord. This can cause a short circuit and a fire.
 - Make sure that the plug of the electrical cord is not squeezed by the back wall of the appliance or otherwise damaged. A damaged plug can be the cause of a fire!
-  Do not try repair the appliance on your own. Always contact an authorized technician. To avoid the exposure to danger, always have faulty cable be replaced only by the manufacturer, by our customer service or by qualified person with a cable of same type.

Requirements for safe use:

- It is forbidden to use a technically damaged appliance.
- If the appliance is unplugged (for cleaning, moving to another place, etc.), it may be repeatedly switched on after 15 min.
- When performing activities, such as cleaning, maintenance or moving, the appliance must be completely disconnected from power supply (by pulling the plug out from the socket). Do not pull on the cord, but hold the body of the plug instead.
- Do not set up the device outdoors.
- In an emergency, pull the power plug out of the socket immediately.
- Do not place any switched on electrical devices on top of the appliance because this may cause ignition of plastic parts. Do not place any dishes with liquids on top of the appliance and do not keep flowers in vases or other liquid-filled vessels on the appliance.
- Do not climb on or sit on the appliance, do not lean on or hang on the appliance doors and do not allow children to do this.
- Do not remove or touch items from the freezer compartment if your hands are wet or damp.

- Do not use water spray and steam to clean the appliance.

 **The appliance should be transported in the vertical position;** do not tilt any more than 30°. The manufacturer will not be responsible for any damage of the appliance that results from non-compliance with the instructions for transportation.

 The manufacturer guarantees reliable operation of the refrigerator when the relative air humidity not greater than 70 per cent and the ambient temperature is:

- +16 TO +32 DEGREES CELSIUS (Climate class **N**);
- +16 TO +38 DEGREES CELSIUS (Climate class **ST**);
- +16 TO +43 DEGREES CELSIUS (Climate class **T**).

INSTALLATION AND OPERATING CONDITIONS

Positioning:

• This appliance can be installed in a dry, well ventilated indoor where the ambient temperature corresponds to the climate class indicated on the rating plate of the appliance.

 Do not install this appliance in areas that are too humid or too colds, such as the construction appendices, garages or wine cellars. Place the appliance away from heat sources such as kitchen stove/oven, radiators, or direct sunlight. The appliance must not touch any pipes for heating, gas or water supply, or any other electrical devices.

Minimum distances from the heat sources:

- from the electric gas and other ovens - 30 mm,
- from oil or coal fired ovens - 300 mm,
- from built-in ovens - 50 mm

If there is no possibility of ensuring the above-mentioned distances, provide an appropriate insulation board

• Do not cover the ventilation holes at the top of the appliances – it must be a good air circulation around the appliance. There should be a gap of at least 10 cm between the appliance body and any furniture that may be requirement is not followed, the appliance electrical energy and its compressor may fig.). ►

• The appliance must stand on a level surface and must not touch the wall. If necessary, regulate the height of the appliance by adjusting

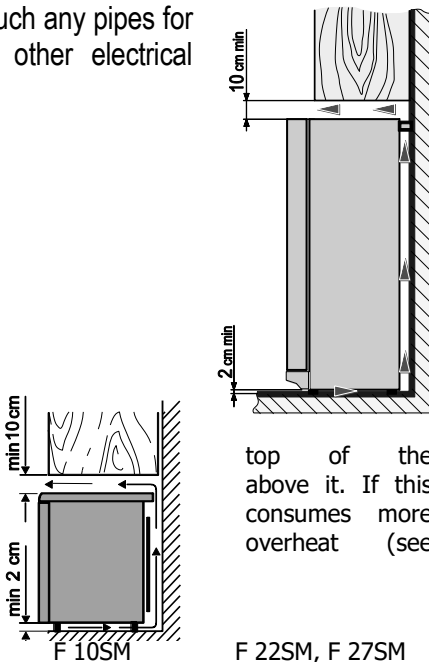

the levelling feet: by turning them clockwise – the front of the appliance rises, by turning them counter clockwise – it comes down. If the appliance is tilted slightly backward – the doors will close by themselves.

- If the appliance is placed in a corner, a gap must be left between the appliance body and the wall so that the freezer compartment door can be opened enough to pull out the frozen product drawer (see fig.).

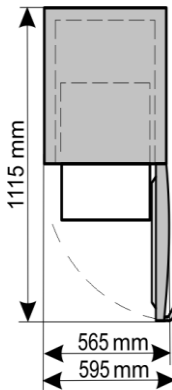

F 10SM

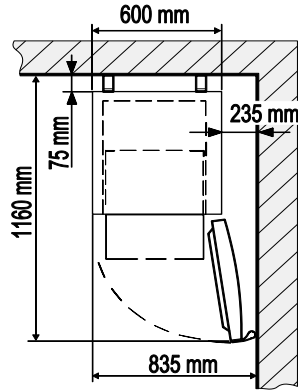

F 22SM, F 27SM

Preparing for operation:

It is recommended to prepare the appliance for operation with a helper.

- The appliance must only be transported in its vertical position; do not tilt any more than 30°.
- Remove package. Lift the appliance away from foamed polystyrene base. Tear off adhesive tapes. Remove all red-coloured parts from the shelves. NOTE. When you open the freezer compartment door a little red packing detail will fall out – it is for transportation purposes only.
- When positioning the appliance F 22SM and F 27SM in chosen location, it will move more easily into position if you lift the front a little and incline it backward, allowing it to roll on its casters.

When placing, moving, lifting the appliance, do not hold the door handles, do not pull the condenser at the rear part of the refrigerator and do not touch the compressor unit.

- When placing F 22SM and F 27SM take two supports **1** from the bag and insert them into the guides **2** at the top back part of the appliance.▶

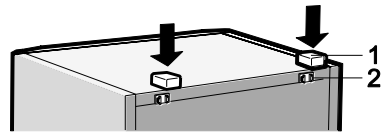

- ☞ The appliance **should not be connected** to the mains until all packing and transport materials aren't removed. Suitably dispose the packaging material.

First use:

Before using the appliance for the first time, the interior and all internal accessories should be washed with lukewarm water and some neutral soap to remove the typical smell of a brandnew product, then dried thoroughly.



If the unit has been tilted more than 30° during transport: wait at least 4 hours before connecting the appliance to the power supply. If this is not done, the appliance compressor may fail.

- When first starting-up or after a period out of use, before putting the products in the compartment let the appliance run at least 2 hours.

DESCRIPTION OF THE APPLIANCE, BASIC PARTS



The appliance accessories listed below may differ from the accessories of the appliance you have bought in quantity and in design. This description is adapted for entire group of freezer.

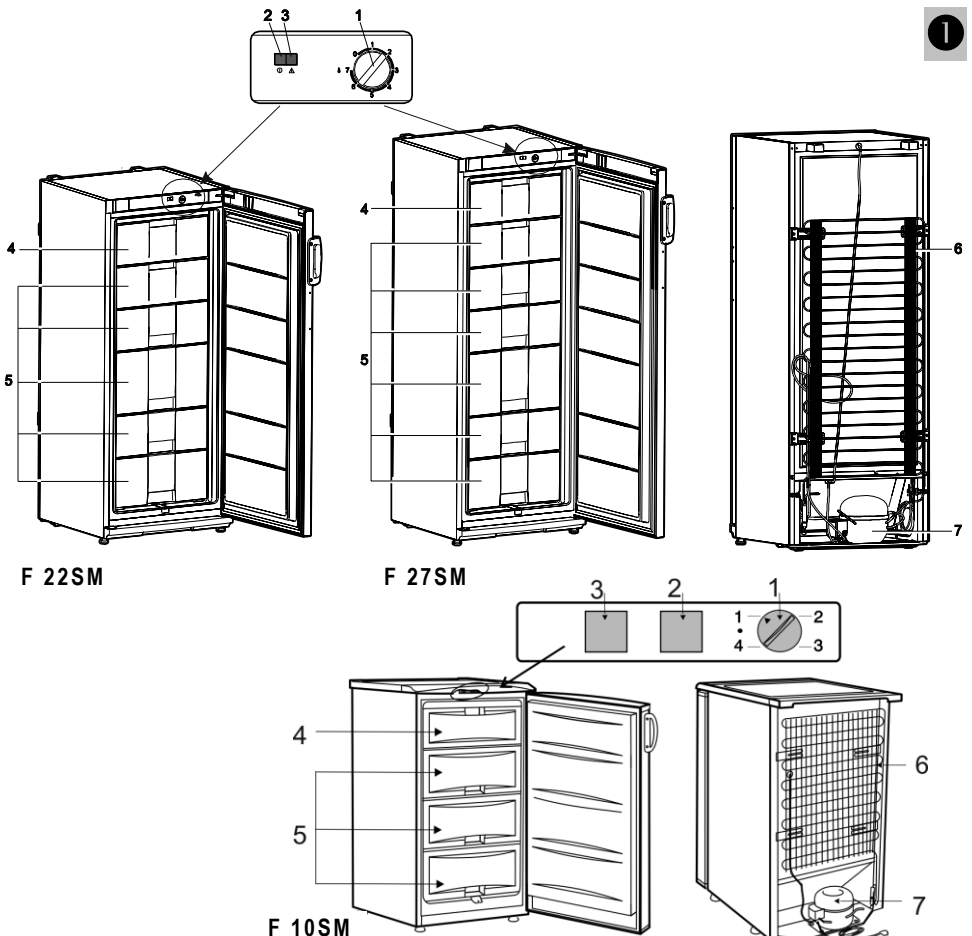

1 Thermostat knob	4 Fast-freeze section
2 Power supply indication	5 Frozen products section(s)
3 Temperature rise indicator (Red color)	6 Condenser
	7 Compressor

- 1** – THERMOSTAT KNOB. The temperature in the appliance is controlled using the thermostat knob by turning it to one side or the other. More in “Temperature regulation”.
- 2** – ELECTRICITY SUPPLY INDICATOR. When the appliance is connected to the electricity supply, the green indicator light is illuminated. Simultaneously also the **the temperature rise indicator lights up**. It indicates that the freezer was switched off for a longer time, i.e. the freezer is switched on for the first time, after defrosting or after losing of voltage. When the temperature in the compartment again falls below -9 °C, the **temperature rise indicator** light will go out.
- 3** – THE TEMPERATURE RISE INDICATOR. When the temperature in the freezer rises above -9 °C, the red indicator light is illuminated. It indicates that:
- The freezer was switched off for a longer time, i.e. the freezer is switched on for the first time, after defrosting or after losing of voltage.
 - The door of the freezer is opened or is being opened too frequently.
 - It is loaded a large amount of unfrozen foodstuffs.
 - **The freezing system is failed, i.e. the indicator does not go out longer 6 hours and it is heard running compressor or the compressor does not switch off. In this case you should apply to your service agent (at first make sure that three above items were taken into account).**

NOTE. The technical data of the appliance can be found on the rating label attached to the inside wall of the appliance. For more information about the appliance, scan the QR code on the enclosed energy label and / or visit the official website of the product database: <https://eprel.ec.europa.eu>

TEMPERATURE REGULATION

Temperature set in the freezer by the manufacturer is -18 °C. Please set the desired temperature in the appliance according to your own requirements.

The temperature in the appliance is controlled using the thermostat knob **1** by turning it to one side or the other. The temperature indication in digits is shown beside the thermostat knob. The number “0, 2, 3, 4, 5, 6, 7” do not mean a specific temperatures.

In the freezers F 22SM and F 27SM the temperature is regulated on the scale of seven digits:

0 = Compressor is switched off. **WARNING! Electric current is not switched off.**

1 = highest temperature (lowest cooling)

7 = lowest temperature (highest cooling)

In the freezer F 10SM the temperature is regulated on a four-digit scale:

• = Compressor is switched off. ATTENTION! The voltage is not switched off.

4 = lowest temperature (maximum refrigeration)
The numbers do not mean a specific temperatures.

 The temperature in the freezer compartment can vary due to the ambient temperature, the amount of food, and the frequent opening of the freezer door.

 IF THE ROOM IS COOL, THE APPLIANCE COOLS LESS. THE TEMPERATURE IN THE APPLIANCE MAY THEREFORE RISE. Use the thermostat wheel to set a lower temperature.

FREEZING AND STORAGE OF FOODSTUFFS

To avoid food contamination, follow the instructions below:

- Prolonged opening of the door can significantly increase the temperature in the compartments of the appliance.
- Regularly clean surfaces that may come into contact with food and accessible drainage systems.
- Store fresh meat and fish in suitable containers in the refrigerator so that they do not come into contact with or drip on other food.
- If the refrigerator is left empty for a long time, switch it off, defrost, clean, dry and leave the door open to prevent mold inside the appliance.

When you intend to freeze fresh food, place it in the fast freeze section **4** (see fig. 1). Transfer frozen food from the quick-freeze compartment to the drawer (s) in the storage compartment.

DO NOT EXCEED THE MAXIMUM AMOUNT OF FROZEN FOOD INDICATED IN THE PRODUCTS DATA SHEET.

- Leave not less than 2.5 cm gap between a top of frozen products and a bottom of drawer, which is over them. ►
- Do not place unwrapped foodstuffs in the freezer sections.
- **Do not refreeze partly thawed products.** Fresh food for freezing should not touch already frozen foodstuffs.
- Do not freeze foodstuffs that are warmer than the room temperature.
- **WARNING!** Do not freeze liquid foodstuffs in glass vessels or bottles.
- Strictly observe the frozen foodstuffs validity dates indicated by the manufacturer on the product packaging.
- **WE RECOMMEND THAT FROZEN FISH AND SAUSAGE SHOULD BE STORED IN THE FREEZER COMPARTMENT NOT LONGER THAN 6 MONTHS; CHEESE, POULTRY, PORK, LAMB – NOT MORE THAN 8 MONTHS; BEEF, FRUIT AND VEGETABLES – NOT LONGER THAN 12 MONTHS.**

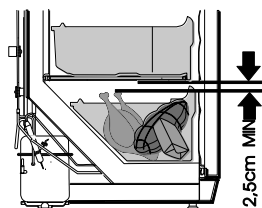

CAUTION! In the event of accidental defrosting, for example due to a power failure, if the power has been off for longer than the value shown in the technical characteristics chart under "rising time", the defrosted food must be consumed quickly or cooked immediately and then refrozen (after cooling).

DEFROSTING, CLEANING AND CARE

The freezer compartment should be thawed not less than twice a year or when a layer of ice thicker than 5 mm forms in it. Do the actions below in the order they are listed:

WARNING! Turn the appliance off and pull the plug out of the electrical socket.

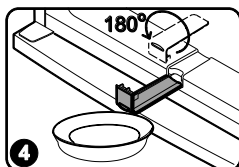

F 10SM

- Remove food from the freezer compartment. The frozen foodstuffs will not warm up too much while you are thawing the freezer compartment if you cover them with a thick cloth and keep them in a cool place.
- F 22SM, F 27SM (see fig. 4): Pull out the melt water gutter, turn it 180° and hook it up. After thawing, place the container with the water gutter.
- Leave the freezer door open. After the frost has thawed, dry the inside of the freezer and the accessories dry.
- F 22SM, F 27SM: Remove the melt water gutter, turn it 180° again and replace it.
- Close the freezer door and turn on.

CLEAN THE FREEZER REGULARLY.



Note: before cleaning the cooling device and its rear compartment part, the device must be disconnected from the mains by unplugging.

- Protect the appliance inner surfaces and plastic parts from fats, acids and sauces. In case of accidental spills – immediately clean with warm soapy water or dishwashing detergent. Wipe dry.
- Regularly clean the hermetic gaskets of the doors. Wipe dry.
- At least once a year clean dust away from the back part of the appliance body and the compressor. A soft brush, electrostatic cloth or vacuum cleaner may be used for cleaning.
- DO NOT use detergents containing abrasive particles, acid, alcohol or benzene for cleaning the appliance inner and outer surfaces. DO NOT use for cleaning cloths or sponges that have coarse surfaces intended for scrubbing

CHANGING THE OPENING DIRECTION OF THE DOORS

It is recommended that changing the opening direction of the doors should be done with a helper. You will need two spanners No. 8 and No. 10 and a head screwdriver.

 When changing the opening direction of the doors, **YOU CAN NOT** lay the freezer horizontally!

- Do the actions below in the order they are listed:

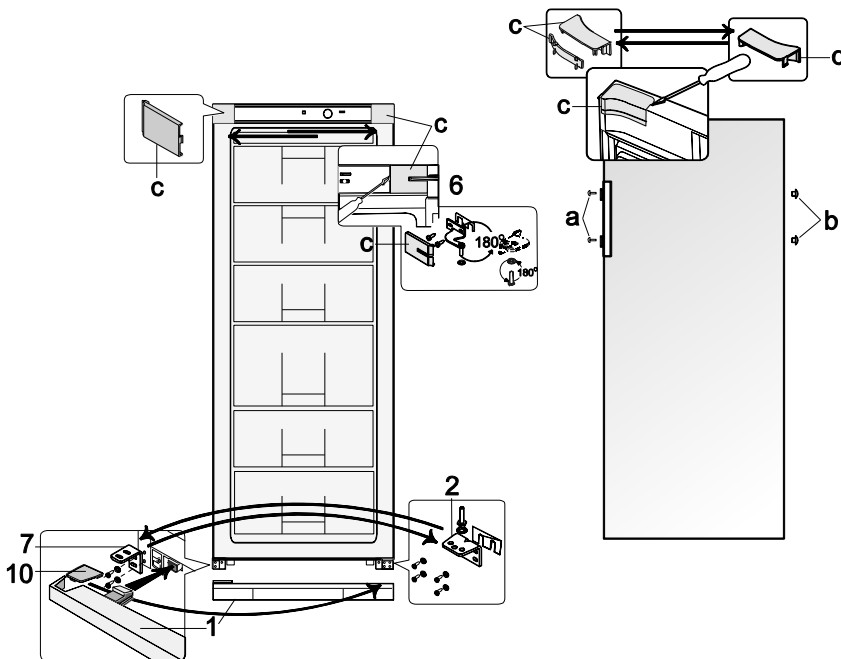

F 22SM, F 27SM:

WARNING! Turn off the freezer and pull the plug out of the electricity supply outlet.

1. Remove covers **c** from the inside of the housing and door and the upper bracket **6** together with the nut and washers and the gasket under the bracket.
2. Remove the freezer door **1**. Remove the stop plate from the bottom **2**. Screw the stop plate (included in the package) on the opposite side of the door to open the door to the left.
3. Remove the bottom cover **3** together with the small cover **4**.
4. Unscrew the shaft **5** together with the washers on the shaft and the catch **8** from the lower bracket **6** and screw them to the bracket **7** on the other side of the cabinet symmetrically to the former position.
5. Push the freezer door onto the bracket **7** on the newly installed shaft **5**.

6. Remove the screw caps **a** and the blinds **b**. Unscrew the **9** fixing screws of the handle and screw the handle on the opposite side of the door. Press the blinds into the remaining holes in the door and place the covers on the screws.

7. Rotate the bracket **6** together with the washers on the shaft and the plastic gasket at an angle of 180°. Unscrew the shaft together with the washers and screw in on the opposite side of the bracket. After inserting the axis **6** of the bracket into the door of the refrigerator compartment, screw it on the opposite side of the refrigerator in the lower holes. Cover **c** with the bracket and the remaining empty cavity.

8. Insert the cover **4** into the guides on the opposite side of the bottom cover **3**. Replace the bottom cover **3** in its original position.

 Wait for about 30 minutes before it is connected to the mains. **If the unit has been tilted to more than 30°, wait for about 4 hours before re-connecting it to the mains.**

F 10SM:

WARNING! Turn off the freezer and pull the plug out of the electricity supply outlet.

1. Remove support **1** and undo screws **2**.
2. Undo the two screws **3** that hold the pull-out shelf.
3. Remove pull-out shelf **4**.
4. Take off bracket **5** together with the washers that are on the axle.
5. Unscrew the axle from bracket **5** together with its washers and screw it into the second aperture of bracket **5**.
6. Remove compartment door.
7. Remove plug **7** from freezer door and press it in on the opposite side.
8. Take off bottom bracket **8** together with the washers that are on the axle. Unscrew the axle by turning it counter-clockwise. Turn bracket **6** around a full 180° and screw the axle back in. Fix the bracket in place on the opposite side.
9. Mount freezer door on the axle of bracket **8**.
10. Fix bracket **5** in place together with the washers that are on the axle.
11. Put the pull-out shelf back in place and replace screws **2** and **3**. Place support **1** in the groove at the top back part of the freezer.
12. Remove bolt caps **a** and plugs **b**. Unscrew the bolts holding the handles in place. Move the handles to the other side. Screw on. Press plugs into the remaining apertures in the door and cover bolts with caps **a**.

 Wait for about 30 minutes before it is connected to the mains. **If the unit has been tilted to more than 30°, wait for about 4 hours before re-connecting it to the mains.**

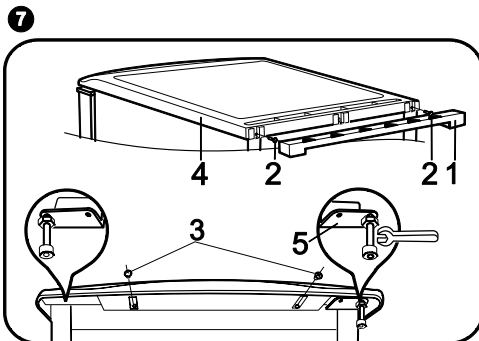

11

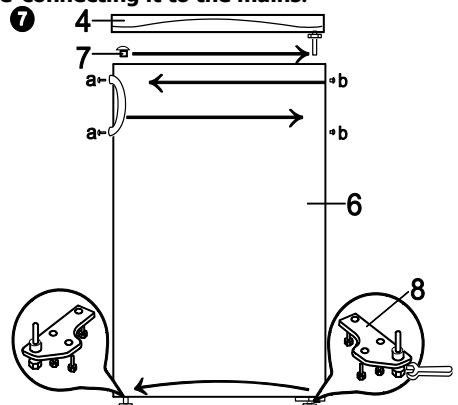

OPERATION PROBLEMS AND THEIR SOLUTIONS

- **The appliance is plugged in to the mains but it does not work and the electricity supply voltage indicator is not illuminated.** Check that your house electricity supply installations are in order. Check that the plug is correctly inserted into the electricity supply socket.
- **The noise has become louder.** Check that the appliance is standing stable on a level place. To make it level, regulate the front feet. Check if the appliance is not touching any furniture and that no part of the refrigeration system at the back part of the appliance body is touching the wall. Pull the appliance away from any furniture or walls. Check that the cause of increased noise isn't due to bottles, cans or dishes in the appliance that might be touching each other.
- **When the appliance door is opened, the rubber sealing gasket pulls out.** The gasket is smeared with sticky foodstuffs (fat, syrup). Clean the sealing gasket and the groove for it with warm water containing soap or dishwashing detergent and wipe dry. Put the rubber sealing gasket back into the place.
- **The temperature rise indicator light is illuminated red.** This means the appliance is being connected to the electricity supply for the first time or it was disconnected for a significant period (for thawing or during an interruption to the electricity supply), the freezer door is not closed or is being frequently opened and closed, or a large amount of fresh food has been put in, and therefore the temperature in the compartment has risen above -9 °C. When the temperature in the compartment again falls below -9 °C, the indicator light will go out.
ATTENTION! If the temperature indicator light does not go out (for reasons other than those listed above) for longer than six hours, the compressor is either working constantly or is not functioning. You need to consult service people.
- **High temperature in appliance, the compressor operation pauses are short.** Ascertain whether the appliance door are shutting tightly, whether the door wasn't kept open longer than necessary when taking out or putting in foodstuffs or whether a large amount of warm food was placed in the appliance.
- **The top of the appliance has condensation on it.** The ambient relative air humidity is above 70 %. Ventilate the room where the appliance stands and if possible remove the cause of the humidity.



Remarks on the appliance operating noise. As the appliance operates and goes through the freezing cycle, various noises will be emitted. This is normal and is not a sign of any malfunction.

- As the refrigerant circulates around the refrigeration system, it causes sounds like murmuring, bubbling, or rustling. Louder sounds like popping or clicking may be heard for a short time as the refrigerator's compressor switches on.

ENVIRONMENTAL PROTECTION INFORMATION

Important Note:

This appliance is marked according to the European directive 2002/96/EC on Waste Electrical and Electronic Equipment (WEEE). By ensuring this product is disposed of correctly, you will help prevent potential negative consequences for the environment and human health, which could otherwise be caused by inappropriate waste handling of this product.



The symbol on the product, or on the documents accompanying the product, indicates that this appliance may not be treated as household waste. Instead it shall be handed over to the applicable collection point for the recycling of electrical and electronic equipment.

Disposal must be carried out in accordance with local environmental regulations for waste disposal. For more detailed information about treatment, recovery and recycling of this product, please contact your local authority, your household waste disposal service or the retailer where you purchased the product.

Our packaging are made of environmentally friendly materials, which can be reused:

- The external packaging is made of cardboard/foil
- The FCKW free shape of foamed polystyrene (PS)
- Polyethylene (PE) foils and bags

The refrigerants and foaming agents, which are 100% free of FCKW and FKW have been used for manufacturing our product. Therefore we are helping to protect the ozone layer and prevent the increase of greenhouse effects. Also, the innovative technology and environmentally friendly insulation help in reducing energy consumption.

RISK FROM OLD APPLIANCE!

Keep children under the age of 8 away from the power cord of the appliance. Keep children away from the packaging materials.

Playing children can lock themselves in the device or get into other life-threatening situations.

- Remove or destroy existing snap locks and bolt locks.
- Do not let children play with the appliance.
- Always supervise children in the vicinity of the old appliance.